

# Metal Barrels

**CUSTOM MANUFACTURED PHOSPHATING  
AND BLACK OXIDE BARRELS**

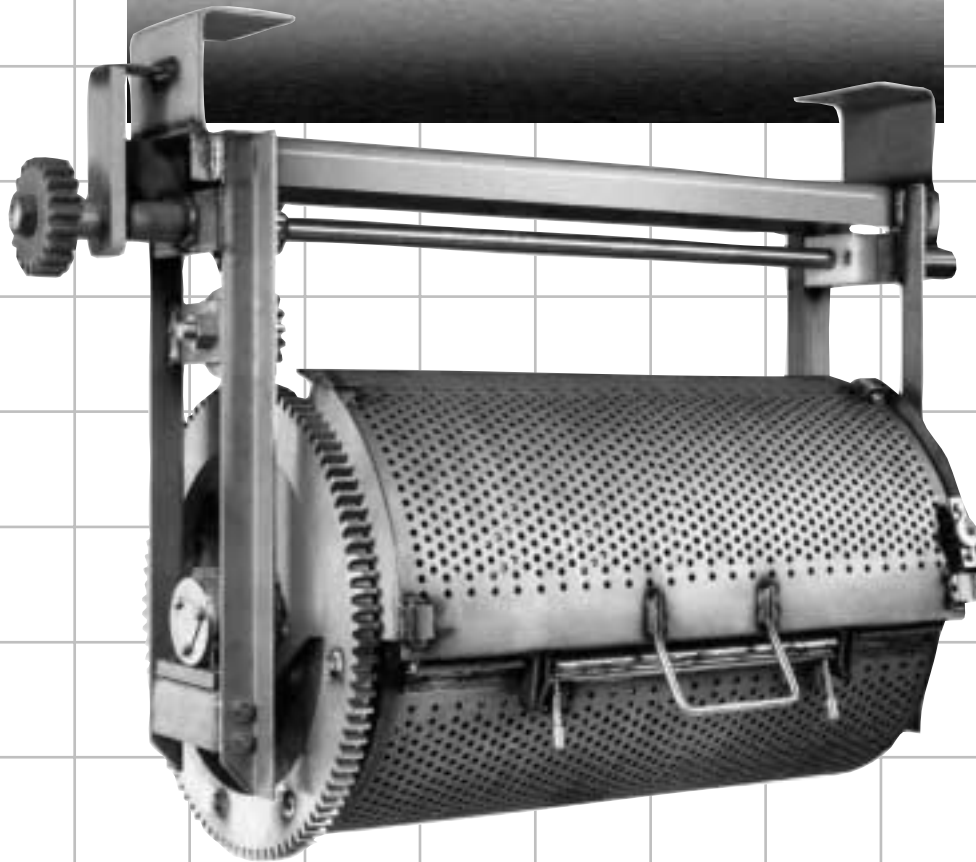

*Using only heavy gauge material and high strength non-corrosive bearings, Hardwood Line has engineered a line of rugged, long life, metal barrels.*

*Designed to withstand the acidic/caustic environment of today's metal finishing shop, Hardwood Line's metal barrels provide maximum durability with minimal maintenance.*

Five Model 2MS6USD 36"x 42" side drive barrels. The round cylinders are constructed of T-316 stainless steel. Attached counter-weighted sliding doors aid the operator in load/unload operations.



**Hardwood Line**  
MANUFACTURING COMPANY



Model 2MS6SUSD 20"x36" gear driven phosphating barrel, constructed of T-316 stainless steel. The hexagon cylinder has 3/16" perforations. The barrel is tank supported with an Angle Iron hangerarm arrangement.



Model 2MSTXOMC 15"x26" gear driven, round, mild steel, barrel. Cylinder is constructed of 12 ga. mild steel with 1/8" perforations. The overhead 1/4 HP fixed speed motor delivers a cylinder speed of 2RPM. The barrel has a Self Standing hangerarm arrangement. A full length polypropylene hood protects components from the drippings of passing barrels.



Model 2MSTBPOMC 12"x18" chain driven barrel is constructed of 12 ga. steel. The hex cylinder has 1/4" perforations. The variable speed overhead air motor delivers a cylinder speed of 2-5 RPM. The barrel has a Self Standing hangerarm arrangement.

## BASIC CONFIGURATION OPTIONS

All Hardwood Line metal barrels are custom manufactured to your requirements. Our Technical Support Department will be happy to assist you in determining the design that will best suit your application and insure that you will receive a barrel that will maximize the efficiency of your operation in the most cost effective way possible.

Listed below are basic options available to you when determining a metal barrel configuration. If you have any questions, please feel free to call us at any time.

**CYLINDER STYLES:** Round or Hexagonal

**MOTORS:** Available as fixed or variable speed, air or electric, in either an Overhead Motor Control or Side Drive style

**PERFORATIONS:**

Four standard sizes; 3/32", 5/32", 1/8", and 3/16" are offered, others available on request (See opposite page)

**DRIVE TRAIN:** Gear (metal or plastic), or Chain

**MATERIALS:** Mild Steel, T-316 stainless steel, T-304 stainless steel, 20 Cb-3, Monel, Inconel

**SUPERSTRUCTURE FRAMES:**

Three basic hangerarm arrangements (illustrated below) are available with or without automatic pickups.

## HANGERARM ARRANGEMENTS

Shown below are the three basic hangerarm configurations. Variables such as angle sizes, materials and chemical resistant coatings are dependent on the application. All hangerarm arrangements feature replaceable cylinder shaft housings and bearing sleeves.

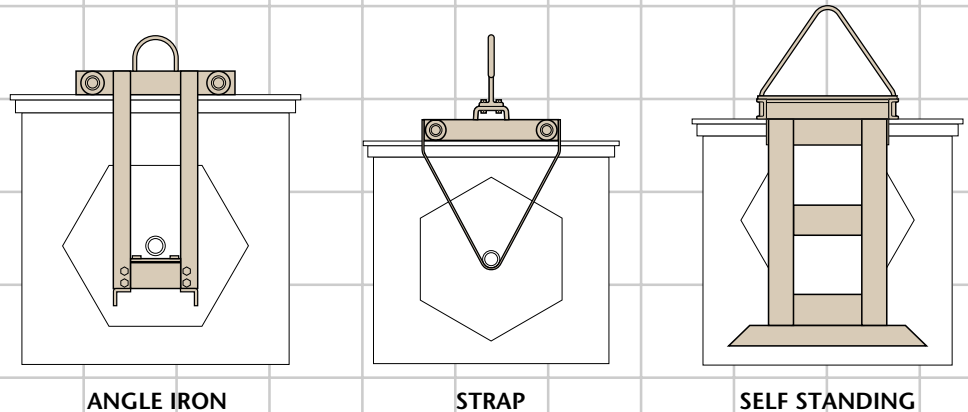

ANGLE IRON

STRAP

SELF STANDING

## CYLINDER SHAFT CONSTRUCTION

Simplified bearing construction allows for easy removal and replacement

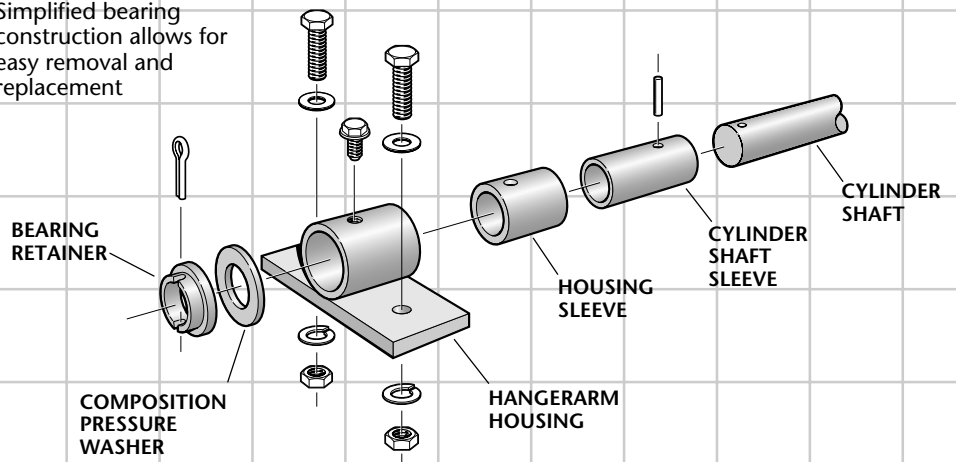

## PERFORATIONS AVAILABLE

Staggered pattern provides a 23% open area while maintaining shell strength. (Perfs shown actual size)

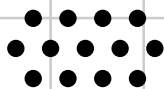

3/32 DIA.

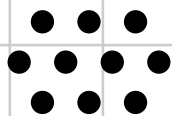

5/32 DIA.

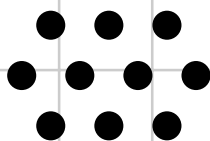

1/8 DIA.

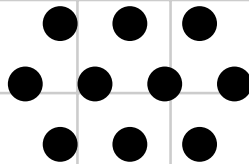

3/16 DIA.

## DOOR LOCKING METHODS

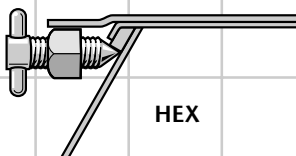

HEX

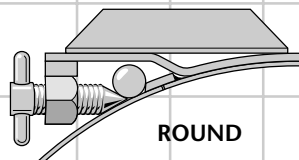

ROUND

Standard turn screws provide positive locking for both hex and round barrels

## HOW TO DETERMINE THE BARREL YOU WILL NEED:

The following information will help us assist you in determining your requirements for either a new system or adding to your existing one.

BARREL SWING CLEARANCE CHART		
BARREL DIA.* (INCHES)	SWING CLEARANCE	
	HEX (INCHES)	ROUND (INCHES)
12	19	17
14	21	19
16	23	21
18	25	23
20	27	25
24	31	29

\*Hex Dia. is measured "flat to flat"

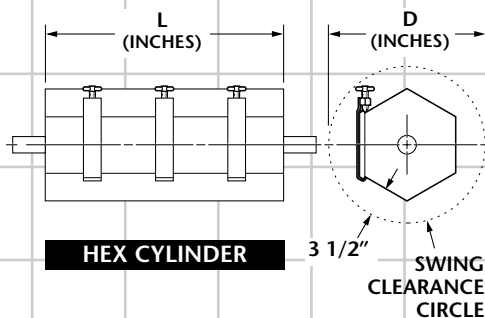

HEX CYLINDER

3 1/2" SWING CLEARANCE CIRCLE

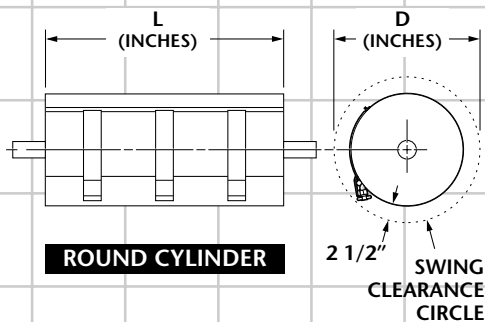

ROUND CYLINDER

2 1/2" SWING CLEARANCE CIRCLE

## CYLINDER VOLUMES

**HEX** TOTAL CAPACITY (CUBIC FEET) =  $\frac{.866D^2 \times L}{1728}$

**RND** TOTAL CAPACITY (CUBIC FEET) =  $\frac{3.14r^2 \times L}{1728}$

(Diameter and Length to be measured in inches)

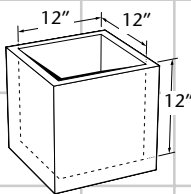

To help determine the gauge of material required, weigh the heaviest parts to be processed in one cubic foot.

Recommended operational load is 1/3 to 2/3 full.

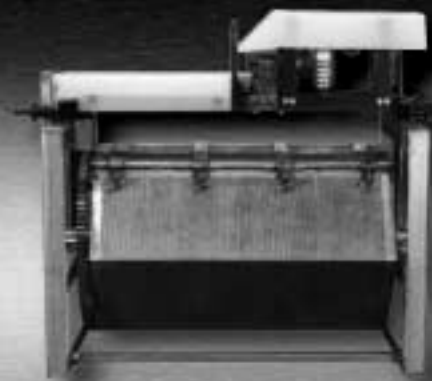

Model 2MMSXHOMC 24"x42" gear driven barrel. The hexagon cylinder is constructed of 12 ga. Monel with 1/8" perforations. The overhead air motor is variable speed and delivers .94 to 2.6 RPM. All components are protected by a polypropylene hood. The barrel has a Self Standing hangerarm arrangement.

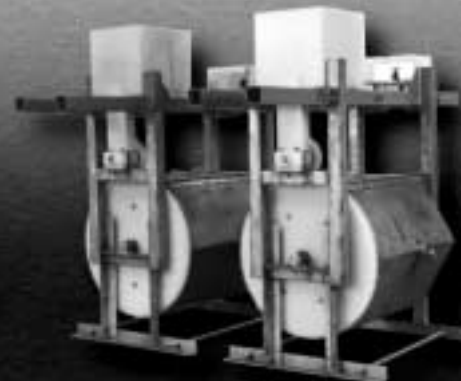

Two Model 2MS6XHOMC 32"x40" hexagon, gear driven barrels. Cylinders are constructed of 7 ga. T-316 stainless steel with 1/4" perforations. The overhead, variable speed air motors deliver a cylinder speed of 2 to 4 RPM. The barrels have a Self Standing hangerarm arrangement. The ends of the upper cross supports are hinged to fold down when not in use. The barrels feature a polypropylene gear with a stainless steel chain drive.



Two Model 2MMUSD 14"x30" gear driven round barrels. Cylinders are constructed of 12 ga. Monel with 1/8" perforations. A 96 tooth cylinder ring provides a 4.6:1 ratio. Upper superstructures are protection coated, mild steel. The barrels are tank supported with a Strap hangerarm arrangement.



Model 2MS4HOMC 14"x30" black oxide processing barrel. The hex cylinder is constructed of 14 ga. T-304 stainless steel with 3/32" perforations. The overhead variable speed air motor delivers a cylinder speed of .92 to 2.8 RPM. The upper superstructure is constructed of protection coated mild steel. The barrel is tank supported with a Strap hangerarm arrangement.

DISTRIBUTED BY:

### IN TANK SWING CLEARANCE

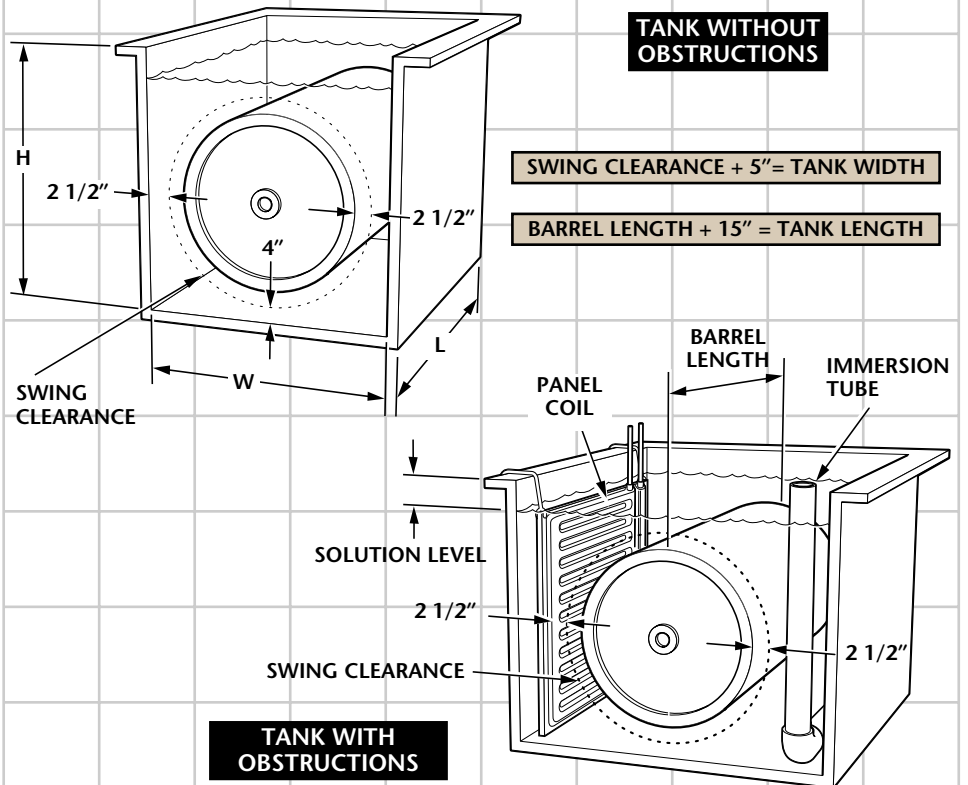

### SIDE DRIVE DATA

To match a barrel to your present system, please provide the following information:

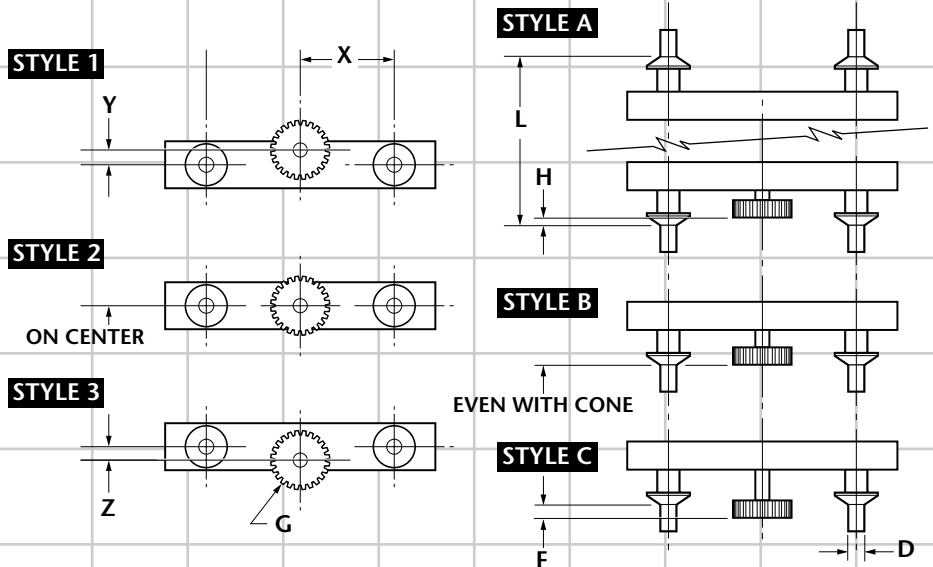

- \_\_\_\_\_ = X (center of gear to center of stud bar)
- \_\_\_\_\_ = Y (distance above center)
- \_\_\_\_\_ = Z (distance below center)
- \_\_\_\_\_ = G (number of teeth and O.D.)
- \_\_\_\_\_ = L (distance of cone to cone)
- \_\_\_\_\_ = H (distance behind cone)
- \_\_\_\_\_ = F (distance in front of cone)
- \_\_\_\_\_ = D (stud bar diameter)



4045 N. Elston Ave., Chicago, IL 60618  
 Fax: (773) 463-9222 Phone: (773) 463-2600  
 email: sales@hardwoodline.com Web Site: www.hardwoodline.com

## 48 x 48 Round Hot Dip Galvanizing Barrels (Model Number 3MSMAOMC)

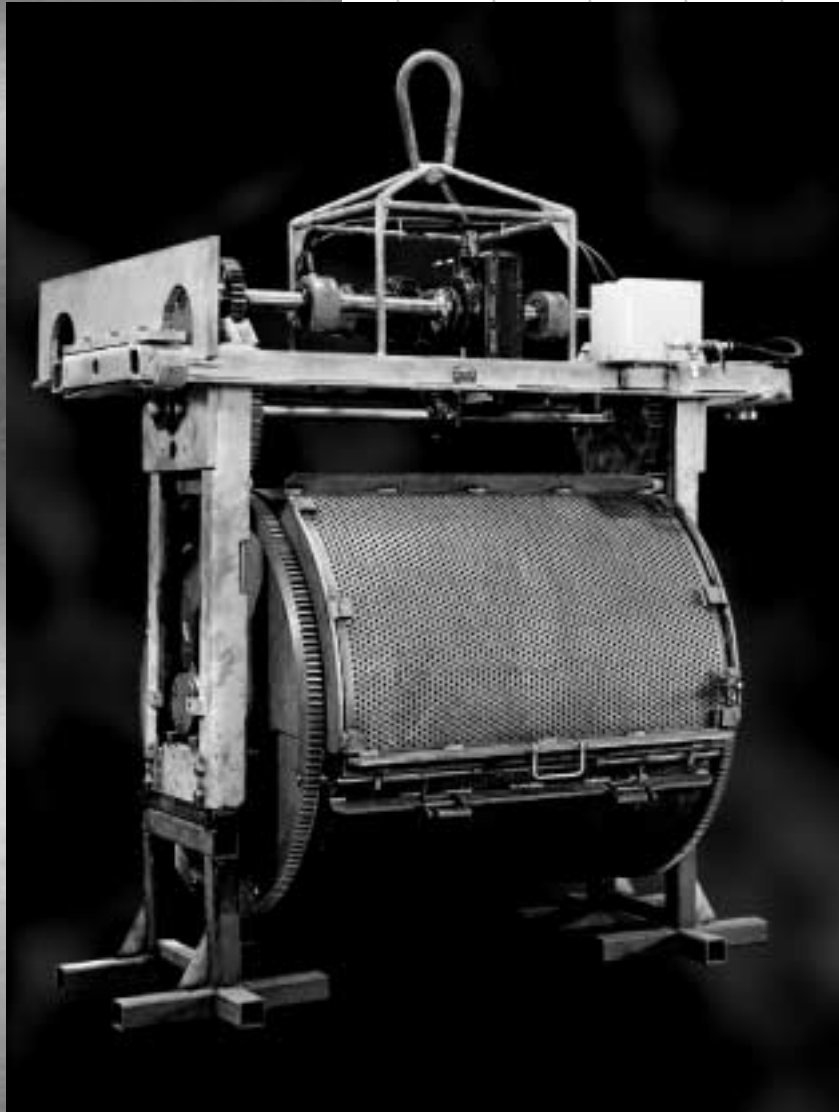

Designed to carry 6000# of work. Radio controlled from a Man/Machine interface. Automatically engages an air supply from tank saddle allowing cylinder to turn from 0-3 rpm's. 3/8" thk round Monel cylinder has 3/8" dia. perf's on 3/4" staggered centers. A counter balanced 180# door is held in place by double 'maze' style locking devices. Revolving cylinder, once unlatched, allows door to revolve around outside of cylinder and into a spring locked position. Door automatically closes by lifting locking pin and reversing cylinder. Each head has an attached 48" dia. Monel 192t ring gear. Superstructure is structural members including 4" x 4" x 1/2" thk framework supports with reducer sized for 20,000 inch pounds of torque.



**Hardwood Line**

MANUFACTURING COMPANY